

# SuperSQV IV D Kit INSTALLATION MANUAL

NAME OF PRODUCT	Super SQV IV KIT
PART NUMBER	7 1 0 0 8 - K T 0 2 0
APPLICATION	TOYOTA VIGO 2009 FORTUNER 2009
ENGINE	2KD-FTV.1KD-FTV

E04531-T77060-00 2011/3/25 Ver.3-1.01

Published in March, 2011 by HKS Co., Ltd. (Unauthorized reproduction is strictly prohibited.)

## NOTICE

This manual assumes that you have and know how to use the tools and equipment necessary to safely perform service operations on your vehicle. This manual assumes that you are familiar with typical automotive systems and basic service and repair procedures. Do not attempt to carry out the operations shown in this manual unless these assumptions are correct. Always have access to a factory repair manual. To avoid injury, follow the safety precautions contained in the factory repair manual.

The HKS SuperSQV IV D Kit is designed to control the excessive air generated inside the chamber pipe once the throttle is released. The SuperSQV IV D makes a unique sound when the air is blown-off from the chamber pipe. The sound will vary depending on the vehicle's specifications.

- This manual indicates items you need to pay attention to in order to install this product safely and lists precautions to avoid any possible damage and/or accidents.
- HKS will not be responsible for any damage caused by incorrect installation and/or use of this product.
- HKS will not be responsible for any labor expenses, related fees or losses incurred during vehicle downtime.
- This product was designed based on installing it onto a factory vehicle. The performance and/or safety cannot be guaranteed if this product was installed onto other inapplicable vehicles.
- The specifications of this product are subject to be changed without notice.
- This manual is subject to be revised without notice.
- For any lost parts, consumables or manual, please contact an Authorized HKS Dealer.

## SAFETY PRECAUTIONS

### WARNING



























- Make sure to work on the vehicle in a well-ventilated area to prevent possible explosion or fire.
- To avoid possible accidents, do not mount the unit in areas where the driver may become distracted during driving or the product cannot be mounted securely.
- Do not install this product on a 24V vehicle. It may cause a fire.
- Make sure to disconnect the negative cable from the battery to avoid possible damage to other electronic parts and/or a fire caused by a short circuit.
- Make sure to hold and remove wire connectors properly to avoid possible damage to other electronic parts and/or a fire caused by disconnection or a short circuit.
- Stop using this product if any unusual problems should occur. Consult your Authorized HKS Dealer immediately.
- Do not operate this product while driving to avoid possible accidents.

### CAUTION

- Do not modify, disassemble, misuse or repair this product and supplied parts to avoid any damage to the product, engine and loss of its original function.
- Handle parts with extra care at all times to protect the parts and vehicle from possible damage.
- Avoid allowing oil and/or water from entering the unit. It may damage the unit.
- Prior to installation, make sure the engine bay temperature has cooled to approximately 40°C /104 ° F. Failure to let the engine cool down properly can lead to severe burns.
- To avoid possible malfunction and damage to the engine, install the unit away from areas with excessive heat and water/moisture.
- Do not tie or bundle any hoses, wires or harnesses to any vehicle fuel lines. It may cause a fire and/or severe damage to the vehicle.
- Make sure all connections and wiring are correct and do not become shorted or disconnected. If so, it may cause an electrical shock or damage the vehicle.
- Use the provided splice connectors and install them to the correct positions. If not, it may cause serious damage to the vehicle.
- Connect the ground wire to a good chassis ground. If not, it may cause damage to the vehicle.
- Insert clean rags into open piping to prevent contaminants from entering the pipes.
  - If neglected, contaminants in the piping can lead to engine damage.

- Make sure that all of the parts listed in the Parts List are included in the kit.
- Reference the factory service manual for the vehicle when removing factory parts.
- Be careful when handling this product; avoid dropping or subjecting it to excessive impact. Failure to do so may result in product damage or improper installation.
- Use the proper tools when tightening nuts and bolts. If over tightened, the bolts may become damaged.
- Keep the removed factory parts in a safe place for ease of re-installation at a later date (if necessary).  
When reinstalling the removed factory parts, make sure to reinstall them correctly.

## PARTS LIST

No.	Description	QT	Image	Remarks	No.	Description	QT	Image	Remarks	No.	Description	QT	Image	Remarks
1	SSQV Assy	1			10	Tie Wrap	5		Small	19	Protection Tube	1		L=300
2	Bolt	1		M6-35	11	Sponge Tape	2			20	Male Bullet Connector & Sleeve	1		
3	Lock Washer	1		M6	12	Boost Drive Controller	1			21	Splice Terminal	2		
4	Flat Washer	1		M6	13	Solenoid Valve	1			22	Heat Shrink Tube	1		
5	Rubber Bushing	2			14	Hose Fitting	2			23	Spade Terminal	1		
6	Hose	1		4mm L=1000	15	Solenoid Bracket	1			24	Electro Tap	3		
7	Air Filter	1			16	Screw	2		M4-8	25	Double-sided Tape	1		
8	Tie Wrap	2		Large	17	Solenoid Valve Wire	1		Orange 2m	26	Instruction Manual	1		
9	Tie Wrap	2		Medium	18	Ground Wire	1		Black 1m	27				

※ The wiring layout and required length of the wires will vary depending on the vehicle.  
 Before connecting the bullet connector, sleeve, splice and spade terminals, carefully measure the length of the wires before cutting.  
 Connect the Solenoid Valve wires using the splice terminals or solder and insulate with the heat shrink tube.

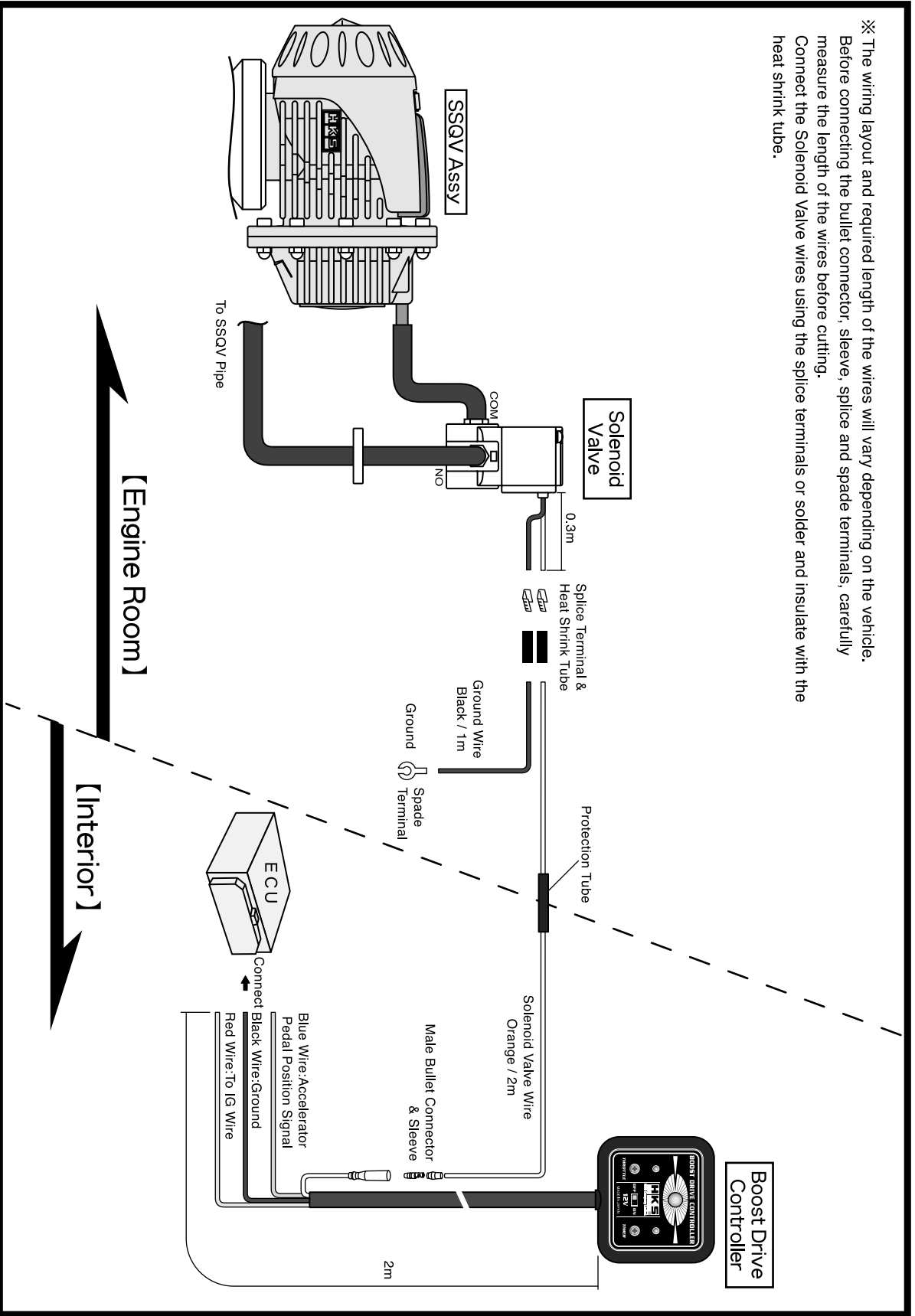

## BEFORE INSTALLATION

- (1) Remove the cable from the negative terminal of the battery.

## INSTALLATION

### 1. INSTALLATION OF SSQV IV D ASSEMBLY

Remove the parts in accordance with the factory service manual.

- (1) Remove the engine cover. (Dia.1)



- (2) Remove 4 bolts and loosen the hose clamp to remove the chamber pipe.  
(The removed bolts and hose clamp will be reused.) (Dia.2)

#### ADVICE:

During removal and installation, make sure no foreign objects get inside the pipes and hoses.

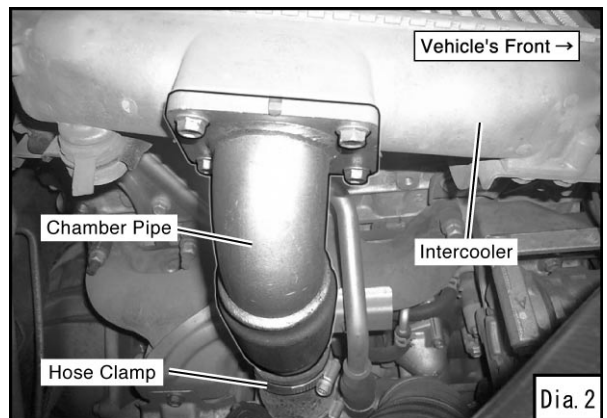

(3) Temporarily install the SSQV Assy. (Dia.3)

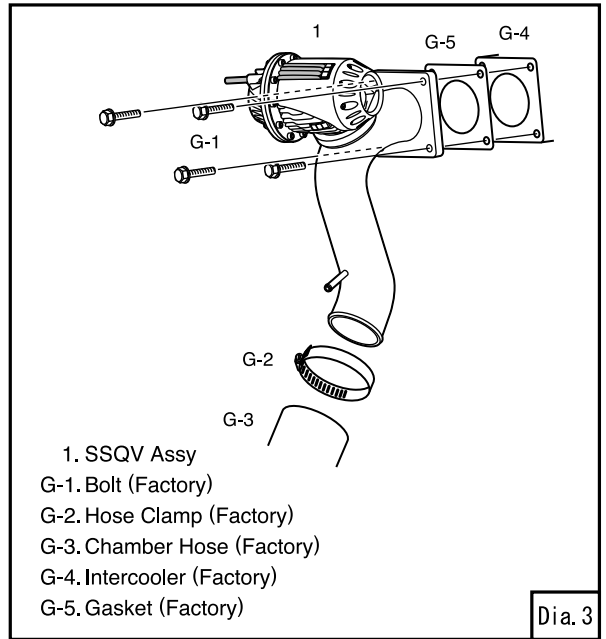

(4) Position the SSQV Assy where it does not come in contact with any other components. Then tighten the hose clamp and the bolts to secure the valve in place.

(5) Reinstall the engine cover.



## 2. INSTALLATION OF SOLENOID VALVE

(1) Remove all 3 caps from the Solenoid Valve. (Dia.5)

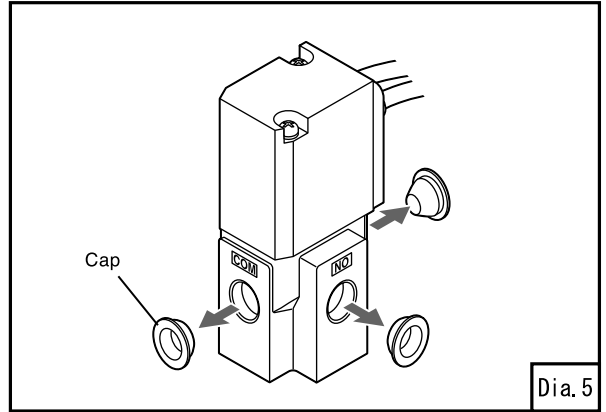

(2) Install the hose fittings to the **COM** terminal and **NO** terminal. Wrap the threaded section with Teflon tape to prevent air leakage. (Dia.6)

### ADVICE:

After tightening the hose fittings by hand, tighten them another one to two turns using the appropriate tools. (It is not necessary to tighten the fittings to the point where the nut touches the pipe.)

When installing the hose fittings, wrap the threaded section with Teflon tape to prevent air leakage,

After tightening the hose fittings by hand, tighten them another one to two turns using the appropriate tools.  
(It is not necessary to tighten the fittings to the point where the nut touches the solenoid valve.)

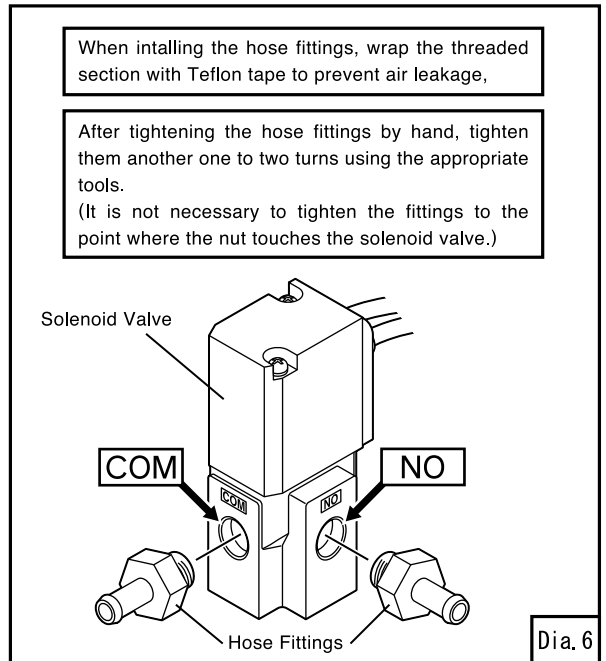

(3) Install the solenoid valve bracket to the solenoid valve. (Dia.7)

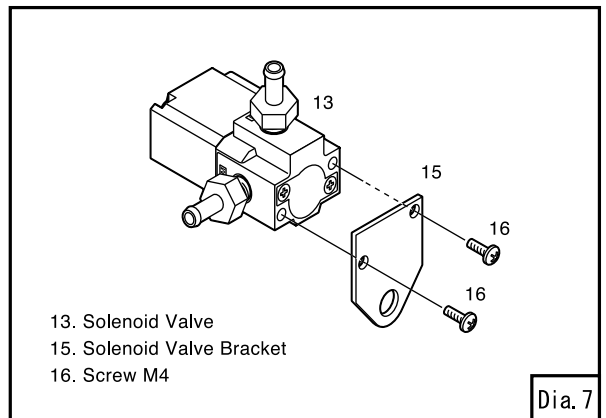

- (4) Install the Solenoid Valve to A using parts in the kit.  
(Dia.8, 9)

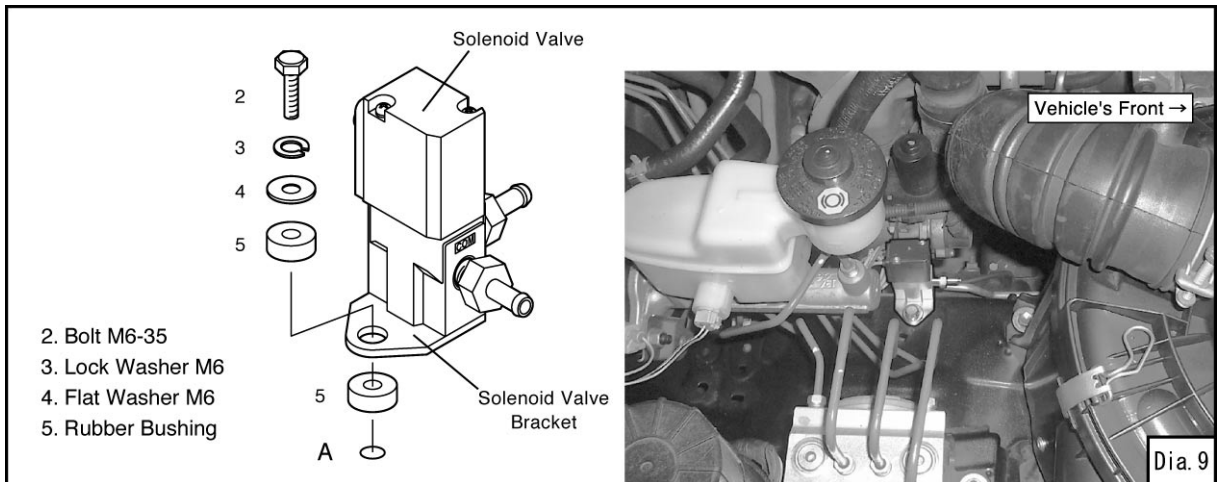
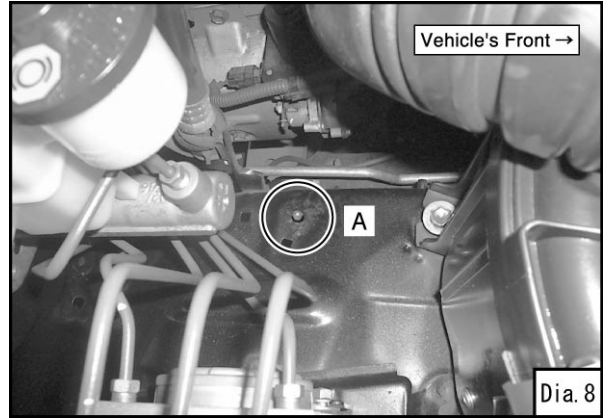



### 3. CONNECTION OF SSQV IV D & SOLENOID VALVE

- (1) Connect the fitting of the **COM** side of the solenoid valve and the SSQV Assy using the supplied 4mm hose. (Dia.10, 11)

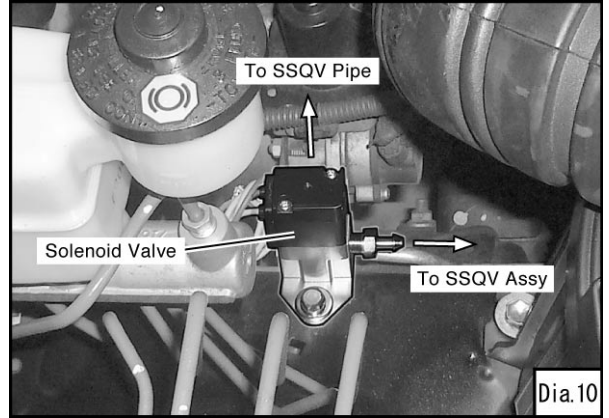

Dia.10

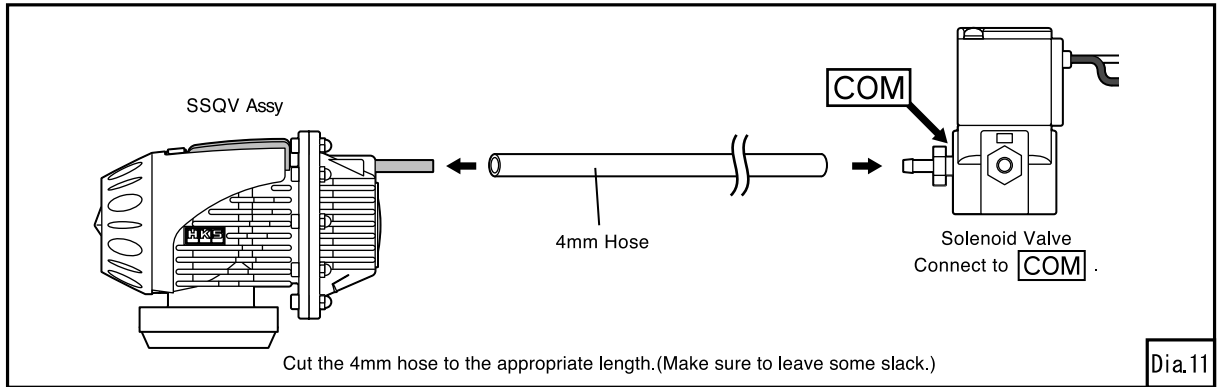

Dia.11

- (2) Secure the 4mm Hose connected to the SSQV Assy Fitting using a tie wrap. (Dia.11, 12)

**ADVICE:**

When uninstalling the SSQV Assy or when removing the 4mm Hose from the SSQV Assy, remove the Tie Wrap, cut the hose past the port on the SSQV Assy, slice the 4mm Hose length-wise and then remove the 4mm Hose. (Dia.12)  
Do not pull or wriggle the 4mm Hose using pliers or other tools to prevent damage to the SSQV Assy.

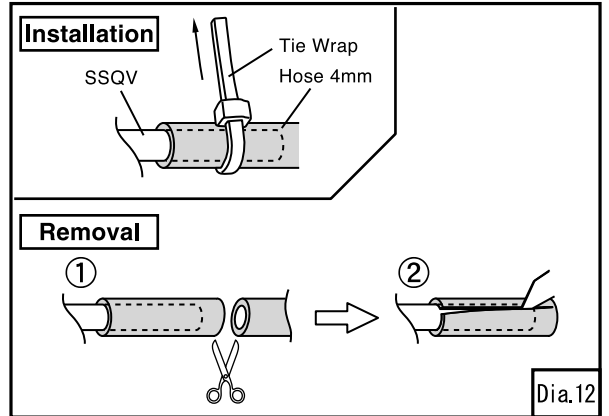

Dia.12

- (3) Connect the fitting of the **NO** side of the solenoid valve and 4mm nipple of the joint pipe using the supplied air filter and the 4mm hose. (Dia.13)

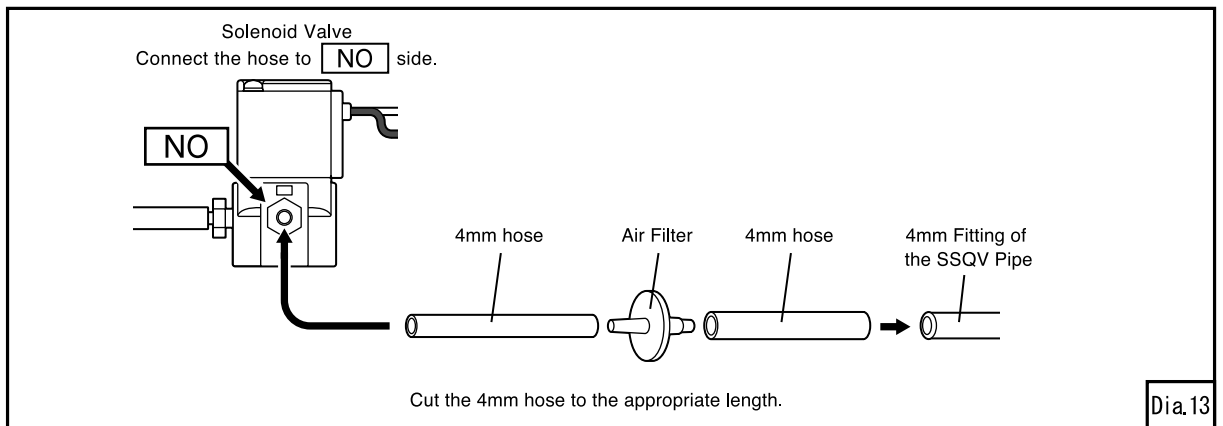

Dia.13

## WIRING / CONNECTION

### 1. SPLICING

- (1) Strip 5mm of insulation off each wire as shown in Diagram 14.
- (2) Twist the wires together.
- (3) Crimp the twisted wires using a splice terminal.
- (4) Insulate the splice terminal and wires by heating the Heat Shrink Tube.

**ADVICE:**

Cut the tube to the appropriate length and slide it over the open end of the wire to get it in the correct position.

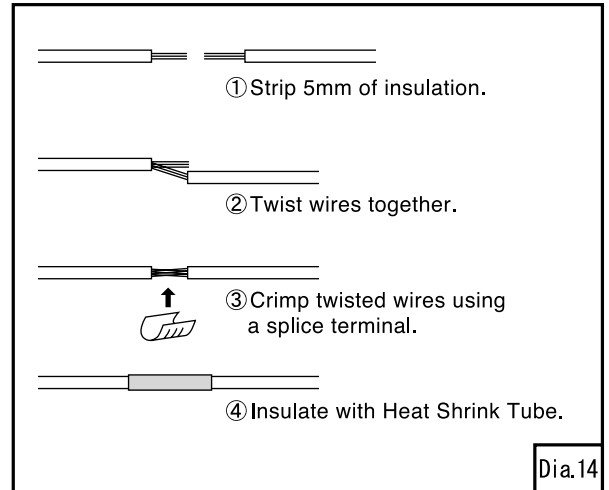

### 2. WIRING

- (1) Connect the orange Solenoid Valve Wire and black Ground Wire to the Solenoid Valve using the Splice Terminals (or solder) and Heat Shrink Tube as shown in Diagram 15.
- (2) Connect the Spade Terminal to the black Ground Wire and connect to a good chassis ground. (Dia.15)

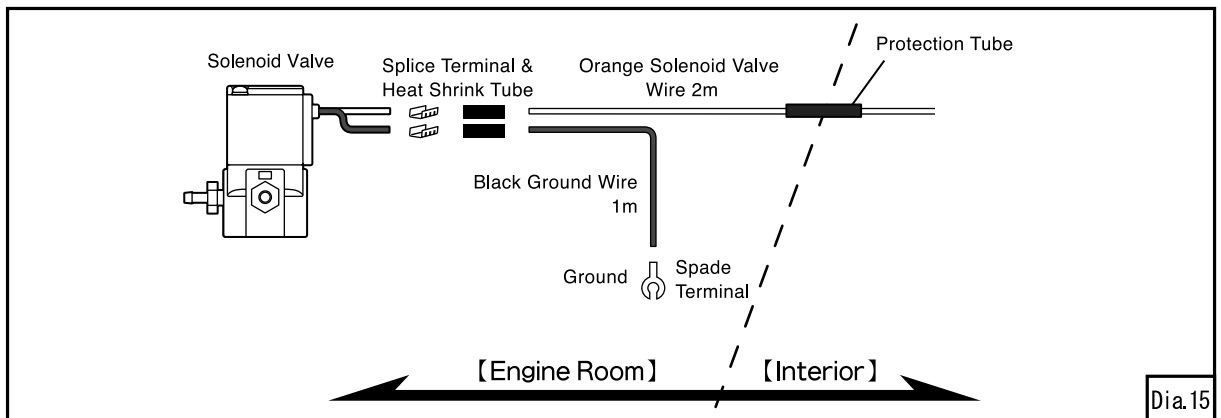

- (3) Pull the orange Solenoid Valve Wire from the engine compartment into the vehicles interior.

**ADVICE:**

Protect the portion of the Solenoid Valve Wire that comes in contact with the vehicles firewall (between the engine compartment and the interior) using the Protection Tube as shown in Diagram 15.

- (4) Connect the orange Solenoid Valve wire to the Boost Drive Controller using the Male Bullet Connector and Sleeve.
- (5) Reconnect the negative cable to the battery.
- (6) Turn the ignition on to find the 12V IG wire using a voltage meter or test light. Disconnect the negative cable from the battery.
- (7) Connect the red wire to a 12V IG source using the Electro Tap.
- (8) Connect the black wire to a vehicle ground wire.
- (9) Connect the blue wire to the accelerator pedal position signal wire using the Electro Tap.

**Make sure to connect all wires correctly to prevent possible malfunctions.**

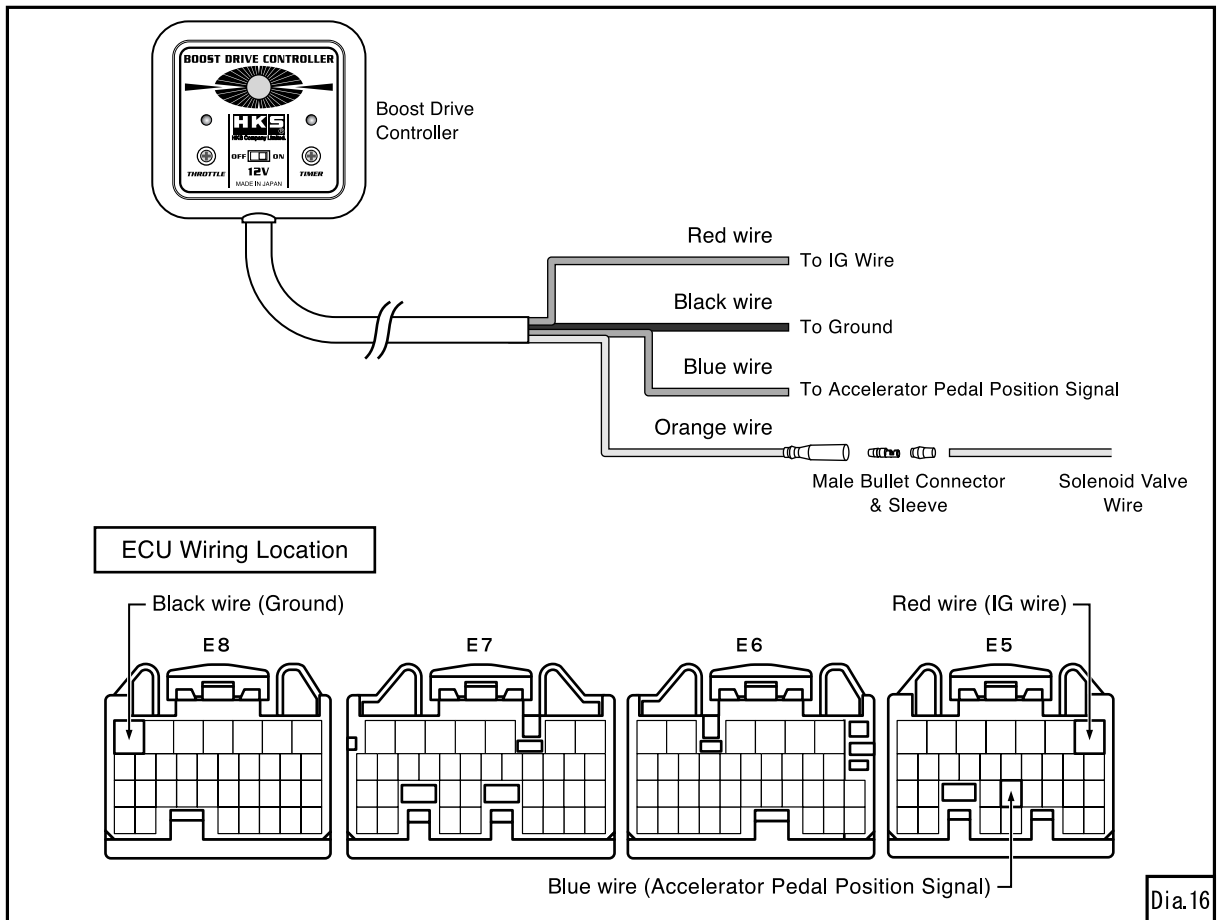

## SETTING THE BOOST DRIVE CONTROLLER (BDC)

### 1. NAMES AND FUNCTIONS

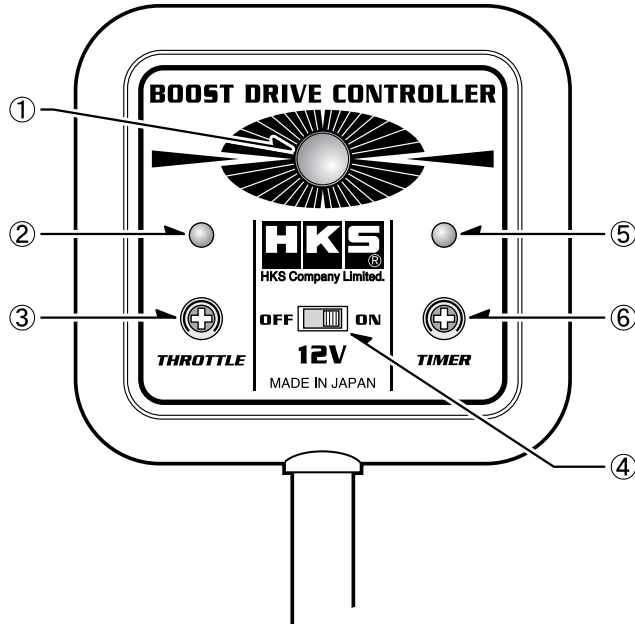

① Trigger Switch

Press this switch to activate the SSQV IV D.  
This switch is also activated when the SSQV IV D is triggered by the accelerator pedal.  
※ If the Trigger Switch is pressed longer than 5 sec., the SSQV IV D will deactivate for safety.

④ ON-OFF Switch

This switch is to turn on and off the SSQV IV D.

※ The SSQV unit may be activated when revving the engine while in neutral even after the switch is off.

② Green Indicator

⑤ Red Indicator

③ Throttle Volume

Turn the volume to set the acceleration start point of the SSQV IV D.

⑥ SSQV IV D Timer Volume

Turn the volume to set the operating time of the SSQV IV D.

### 2. INDICATOR CONDITIONS

	Idling	During Acceleration	Accelerator OFF SSQV ON	Accelerator OFF OFF	BDC Switch OFF
Green Indicator	● ON			● ON	—
Red Indicator		● ON			—
Trigger Switch			● ON		—

### 3. OPERATION SETTING

#### ADVICE:

Turn the volume slowly to prevent any damage to the product.

(1) Set the acceleration position to activate the SSQV IV D by turning the Throttle Volume ( ③ on page 12).

1. Start the engine and let it idle.
2. Turn the ③ volume to the far left; then, turn the volume to the right slowly until the ① Trigger Switch turns on.  
A few seconds later, the ① Trigger Switch will turn off, and the ② Green Indicator will turn on. If the ② Green Indicator is not on, turn the volume to the right a little more.

The Throttle Volume setting is now complete.

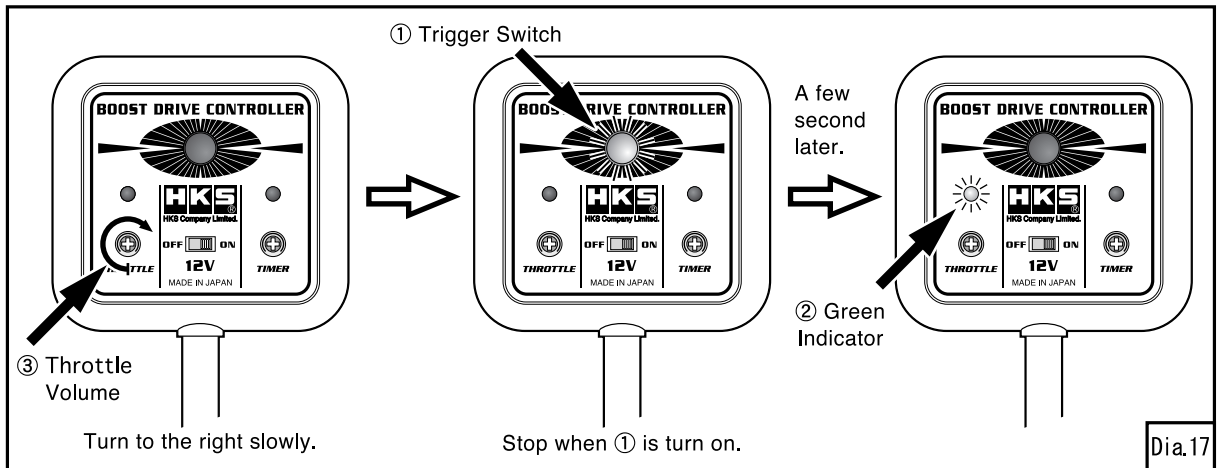

(2) Set the operating time of the SSQV IV D by turning the Timer Volume ( ⑥ on page 12).

1. Turn the ⑥ volume to the far right. If the operating time of the SSQV IV D (Solenoid Valve) is activated too long, turn the ⑥ volume to the left to shorten the time.  
The setting range is between approximately 0 to 8 seconds; the far left volume is 0 seconds.

The Timer Volume setting is now complete.

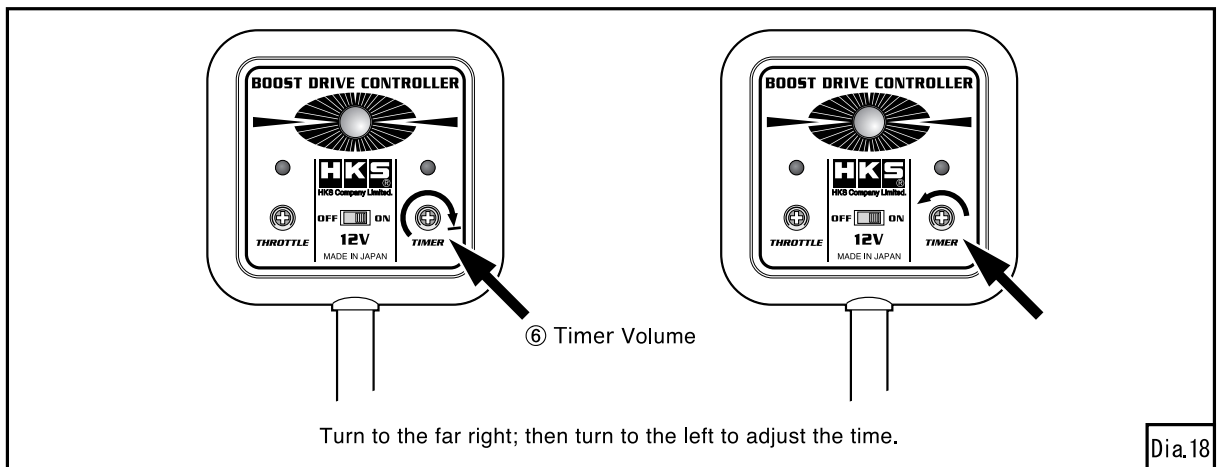

## MOUNTING BOOST DRIVE CONTROLLER

### 1. MOUNTING BOOST DRIVE CONTROLLER

- (1) Remove any dirt, dust and/or oil from the mounting surface of the Boost Drive Controller.
- (2) Mount the BDC using the double-sided tape.

### 2. SECURING HOSES AND WIRES

- (1) Secure all hoses and wires using the provided Tie Wraps.

#### ADVICE:

Leave some slack when routing the wires and hoses to avoid tension during engine movement. When tying the hoses, make sure not to pinch the hoses.

## AFTER INSTALLATION

- (1) Reinstall all removed factory parts.
- (2) Reconnect the negative cable to the battery.

## CONFIRMATION AFTER INSTALLATION

Check the following after the installation process is complete.

- (1) Check the following before starting the engine:
  - Make sure all pipes and hoses are routed and connected correctly.
  - Make sure there are no loose hoses.
  - Make sure hoses are not damaged in any way.
  - Make sure all hose clamps are tightened.
  - Make sure all bolts and nuts are tightened.
  - Make sure all installed components do not come in contact with other parts.
  - Make sure hoses and wires are properly secured.
  - Make sure wiring is done correctly.
  - Make sure splice connectors are connected securely.
  - Make sure proper splice connectors are used and crimped securely.
  - Make sure the installed parts are mounted securely and do not interfere with driving.
  - Make sure the negative cable terminal is securely attached to the battery.
- (2) Start the engine and check the following:
  - Make sure air is not leaking.
  - Make sure the RPM rises smoothly after revving the engine 2-3 times while in neutral.
  - Make sure the installed parts are not hitting each other.
  - Make sure there are no idling issues.
  - Make sure there is no excessive tension on hoses and/or wires.
  - Make sure there are no loose bolts after turning off the engine. Re-tighten if necessary.

## How to install the Super SQV Recirculation Fitting

If it is necessary to recirculate the SSQV IV D back into the suction pipe, please refer to the instructions below. Miscellaneous hose clamps, suction pipe fitting, and return hose are not included in this kit.

1. Remove 4 bolts (per diagram) and remove the cover.

### NOTE

Do not remove the remaining 4 bolts as they are to stay affixed to the SSQV main body.

2. After removal of the cover, the recirculation fitting can be removed.
3. Install the Recirculation Fitting. Reinstall the cover and retighten the 4 bolts.

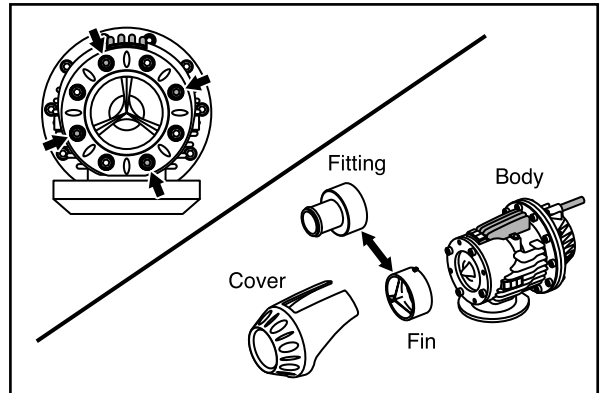

## MAINTENANCE

Proper maintenance of this product is necessary in order to maintain the safety, reliability, and function of this product.

- Maintenance is the responsibility of the driver/owner.
- If work needs to be performed outside the scope of this manual, consult a professional.
- For optimal performance, it is recommended to replace the air filter every 3,000-5,000km or every 3-6 months. Replacement air filters are sold separately.
- If the vehicle gets damaged, have the repairs performed by a professional.
- If you experience any abnormal noises, scents, or vibrations from the vehicle while driving, reference the vehicle's Service Manual.
- If this product is ever re-sold, please give this Instruction Manual to the new owner.
- When removing this product from the vehicle, please consult a professional.

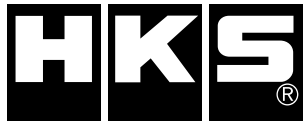

株式会社 エッチ・ケー・エス  
〒418-0192 静岡県富士宮市北山7181  
<http://www.hks-power.co.jp/>

( 禁無断複写、転載 )